

DrillVision Ex Rated Dome PTZ

Explosion Proof 33x Dome PTZ Camera



Key features

- Class 1 Division II
- Highest protection: IP68
- Double ex-proof marking: :Ex d & Ex tD
- Wide voltage: AC24V, AC100-240V
- Stainless steel 304/ 316L housing
- Intelligent telephoto speed limits
- 360° endless Auto tracking
- 300 points patrol preset
- Wall/ ceiling mounted version
- can load 5inch, 6inch brand dome camera

Application

Ex Dome with stainless steel housing, protect camera against fire, explosion, 316L grade version for marine high corrosion environment. applied for industrial, hazardous area, marine and highly corrosive environments..

Description

Ex Dome is a stainless steel camera housing has been designed to protect cameras installed in highly aggressive area. 316L grade housing for marine, since seawater is high corrosion and salty. With optional communication protocol and wide range of voltage. 360°endless auto tracking.

Specifications

Explosion proof Marking	
Marking	Ex d II CT6 Gb/ Ex tD A21 IP68 T80° C
CNEX Certification No.	CNEX15.3070X
Mechanical	
Enclosure material	Stainless steel 304 or 316L
Ingress protection	IP68
Threaded hole	1pcs G3/4 or NPT3/4
Wiper	No
Rotation speed	0~200°/Second
Sunshade	Optional
Net weight	15Kg
Dimension	Φ213 x 213 x 570 (mm)
Environment	
Mount	wall, pole
Operating temperature	-25 to +60°C
Air pressure	80KPa~106KPa
Relative humidity	≤95% (no condensation)
Electrical	
Working voltage	AC24V ± 25% or DC24V ± 25% or POE (IEEE802.3at)
Power	Max 16W
Optional choice	Heater, cooling, thermostat for below -10°C temperature
Electric current	2800mA
Communication protocol	TCP/IP/PELCO-D/PELCO-P, other
Output mode	RJ45
Preset	300 Points, accuracy <0.1° (optional 256 points)
Cable connection	Network cable + 3-core power



DrillVision™

Onshore, Offshore, Facilities, Pipelines

A Southern Electronics Company

2301 Julia St.
New Orleans, LA 70119
225.753.8884

www.drillvisionsystems.com

Specifications:

CAMERA	
Image Device	1/2.8" 2MP Progressive Scan CMOS
Resolution	1920(H)x1080(V)
Minimum Illumination:	Color 0.001 Lux / F1.5 B/W: 0.0001 Lux / F1.5
White Balance	Auto/Manual/ATW/Indoor/Outdoor/Daylight lamp/ Sodium lamp
AGC	Auto/Manual
S/N Ratio:	≥ 52dB
Shutter Time	Auto/ Manual, 1sec-- 1/10,000 sec
Day & Night	Auto ICR
Digital Zoom	16X
Privacy Masking	8 privacy masks programmable
Auto Focus	Auto / Semi-automatic / Manual
3D DNR	support
BLC	support
WDR	120dB
HLC	support
Defog	support
Focal Length	4.5-148.5mm, 33X optical
Zoom Speed	Approx.2.7s(Optical Wide-Tele)
Angle of View	56.7 to 2.28 degree (Wide-Tele)
Minimum Working Distance	0-1500mm(Wide-Tele)
Aperture Range	F1.5-F4.0
Proportional zoom	Rotation speed can be adjusted automatically
Movement range (pan)	360° endless
Pan speed	Configurable, from 0.1°/s to 250°/s, preset speed:300°/s
Movement range(tilt)	From -5° to 90°
Tilt speed	Configurable, from 0.1°/s to 150°/s, preset speed:200°/s
preset	300
Patrol scan	8 patrols, up to 32 presets per patrol
Pattern scan	4 pattern scans, record time over 10 minutes for each scan
Pack action	Preset/pattern scan/ patrol scan/ auto scan/ tilt scan/ Random scan/ frame scan/ panorama scan
Scheduled Task	Auto scan/ frame scan/random scan/ patrol/pattern/ preset/ panorama scan/tilt scan/ dome reboot/dome adjust/aux output
Detection	Intrusion Detection, Line crossing detection
ROI encoding	Main stream, sub-stream and third stream respectively support two fixed areas.
Max resolution	1920*1080
Main stream	50Hz:25fps(1920*1080,1280*960,1280*720) 50fps (1280*960,1280*720)60Hz:30fps(1920*1080,1280*9 60,1280*720) 60fps(1280*960,1280*720)

GENERAL	
Sub-stream	50Hz:25fps(704*576,640*480,352*288) 60Hz:30fps(704*480,640*480,352*240)
Third stream	50Hz:25fps(1920*1080,1280*960,1280*720,704* 576,640*480,352*288) 60Hz:30fps(1920*1080,1280*960,1280*720,704* 480,640*480,352*240)
Video compression	Ultra 265, H.265, H.264, MJPEG
Audio compression	G.711
Protocols	IPv4 IPv6, HTTP, HTTPS, 802.1x,Qos, FTP, SMTP, UPnP, SNMP, DNS, DDNS, NTP, RTSP, RTP, TCP UDP, IGMP, ICMP, DHCP, PPPoE
Simultaneous live view	Up to 20 channels
User/ Host	Up to 32 users 3 levels: administrator, operator and user
Security Measures	Password protection, Multiple access control
Optional Alarm input	2-ch alarm inputs
Optional Alarm output	1-ch alarm output
Optional Audio Input	1-ch audio input
Optional Audio Output	1-ch audio input
Network interface	1pcs of RJ45, support 10M/100M/1000M
Web Browser	IE7+ Chrome 18+, Firefox 5.0+, Safari5.02+

DrillVision™

Onshore, Offshore, Facilities, Pipelines

A Southern Electronics Company

2301 Julia St.
New Orleans, LA 70119
225.753.8884

www.drillvisionsystems.com

Specifications:

Dimensions and Accessories

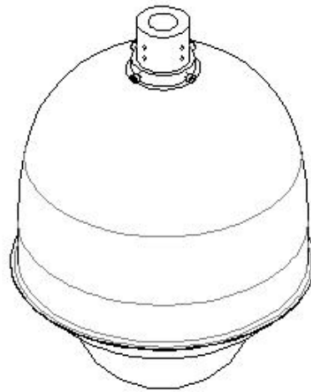
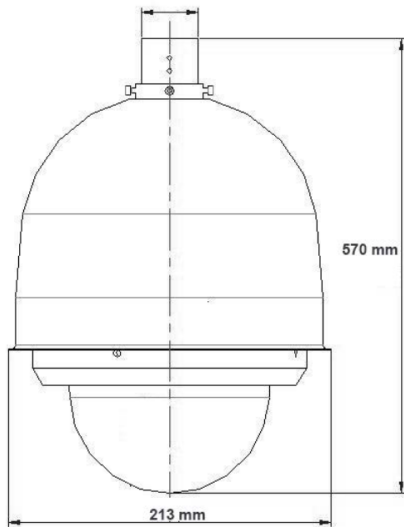

wall bracket



ceiling mounted bracket

DIVISION™

Onshore, Offshore, Facilities, Pipelines

A Southern Electronics Company

2301 Julia St.
New Orleans, LA 70119
225.753.8884