

## EXH – Explosion Proof Housing



Driller's  
Choice!

### DESCRIPTION

The EXH housings are made with strong Anticorodal aluminium die-cast alloy of AISi Mg EN AB- 42000 group.

The cylindrical body of the EXHC housing (210mm diameter and 400mm length) is closed on opposite sides by two 12 mm thick flanges. The housing is supplied with two holes for the 3/4" NPT cable glands. The camera housing is equipped with heater and optional sunshield.



### KEY FEATURES

- Designed to meet the strictest international standards and to operate in hazardous areas
- Solid, non corrosive die-cast aluminium construction
- 2 holes for cable glands 3/4" NPT
- Ambient temperature: -40°C/+50°C (-40°C/+122°F) with reinforced heater



# Specifications

## GENERAL

- Non-corrosive die-cast aluminium (anticorrosive)
- Epoxy powder painted with orange peel effect, RAL7032

## MECHANICAL

- 2 holes for cable glands 3/4" NPT
- External dimensions:
  - EXHC Ø 210mmx427.5mm (8.2x16.8in)
- Internal dimensions:
  - EXHC Ø 180x380mm (7x14.9in)
- Internal usable area:
  - EXHC 100x100x280mm (3.9x3.9x11in)
- Glass window extra clear:
  - EXHC Ø 114mm (4.5in)
- Unit weight:
  - EXHC 15kg / 33lb

## ELECTRICAL

- Reinforced heater: Ton 15°C±4°C (59°F±7°F), Toff 22°C±3°C (72°F±5°F)
- 3 resistors in the housing, consumption 60W max
- Glass protection device:
  - 24Vac, power consumption 2W max
- Devices to install inside the housing
- Camera equipped with lens with max total power of 20W
- Voltage max. 24Vac or 230Vac
- Useful volume for camera / lens: 2800cm<sup>3</sup>

- Minimum distance between the walls of the housing and the camera/lens: 12mm

## ENVIRONMENT

- For installation indoors and outdoors
- Operating temperature with heating: -40°C / +50°C (-40°F/+122°F)
- Always refer to the temperature in the marking.

## CERTIFICATIONS

- Electrical safety (CE): EN62368-1
- Electromagnetic compatibility (CE): EN601000-6-3, EN61000-3-2, EN61000-3-3, EN50130-4, EN55032 (Class B)
- RoHS (CE): EN50581
- Outdoor installation (CE): EN60950-22, ICE60950-22
- IP protection degree (EN/IEC60529): IP66

## CERTIFICATIONS - EXPLOSION-PROOF APPLICATIONS

- ATEX (EN 60079-0+A11, EN 60079-1, EN 60079-31)
- IECEx (IEC 60079-0, IEC 60079-1, IEC 60079-31)
- EAC EX (TR CU 012/2011)
- KCs (Employment and labor department 2016-54)

**Drill**Vision™

**Onshore, Offshore, Facilities, Pipelines**

*A Southern Electronics Company*

2301 Julia St.  
New Orleans, LA 70119  
225.753.8884

[www.drillvisionsystems.com](http://www.drillvisionsystems.com)

# Specifications

The indicated measurements are expressed in millimetres.

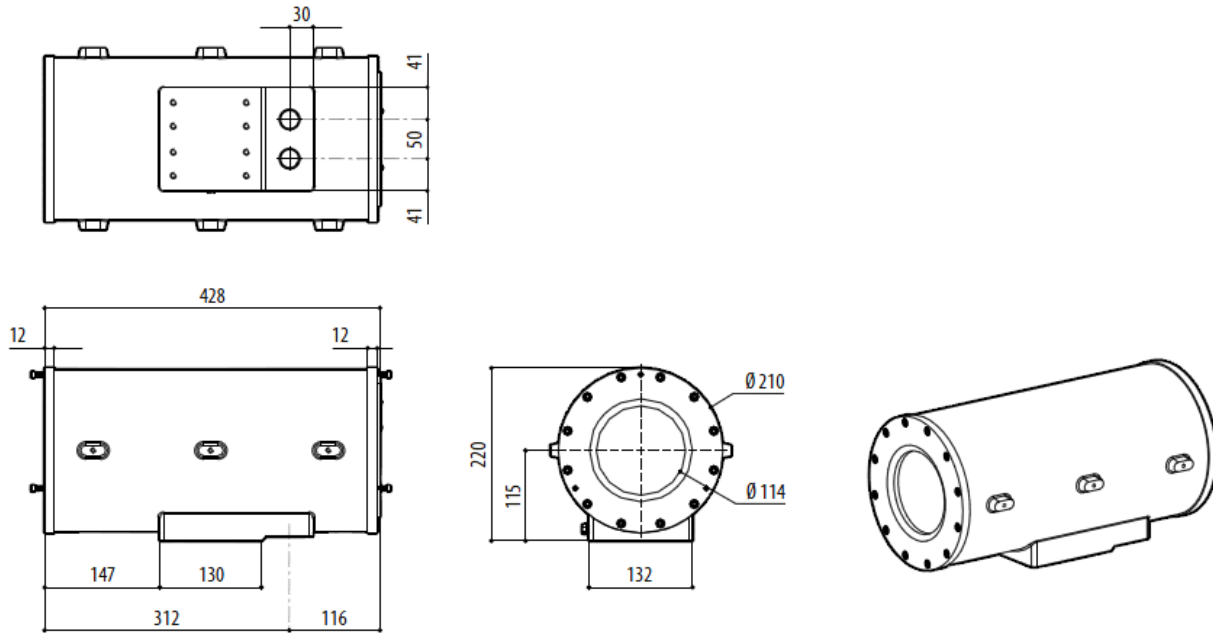

EXHC

**Drill**Vision™

Onshore, Offshore, Facilities, Pipelines

A Southern Electronics Company

2301 Julia St.  
New Orleans, LA 70119  
225.753.8884

[www.drillvisionsystems.com](http://www.drillvisionsystems.com)